

AMERICAN COOLER TECHNOLOGIES

**INSTALLATION INSTRUCTIONS FOR
COOLERS/FREEZERS WITH SCREED**

NSF INSTALLATION GUIDE

PLEASE READ CAREFULLY BEFORE PROCEEDING WITH INSTALLATION

All ACT Projects are shipped complete with detailed drawings indicating location of floor screeds, walls, tops and interior partitions.

All sections are numbered at the factory and will correspond with the identification numbers indicated on the detail drawings.

**FOR PROPER SET-UP DO NOT
DEVIATE FROM THIS NUMBERING SYSTEM****FOR NSF LISTED PRODUCT DO NOT DEVIATE FROM
INSTALLATION INSTRUCTIONS****INFORMATION INCLUDED IN THIS PACKAGE**

- 1. Cover Page
- 2. Detail Drawings for Locating Floor Screeds, Walls & Tops
- 3. Floor Screed Installation Details
- 4. Wall Section Installation Details
- 5. Top Section & Trim Cap Installation Details
- 6. Door Jamb & Bracket Installation Details
- 7. Other Sheets

American Cooler Technologies

900 Crandall Parkway
Lawrence, MI 49064
Phone: (269) 674-8144
Fax: (269) 674-3561

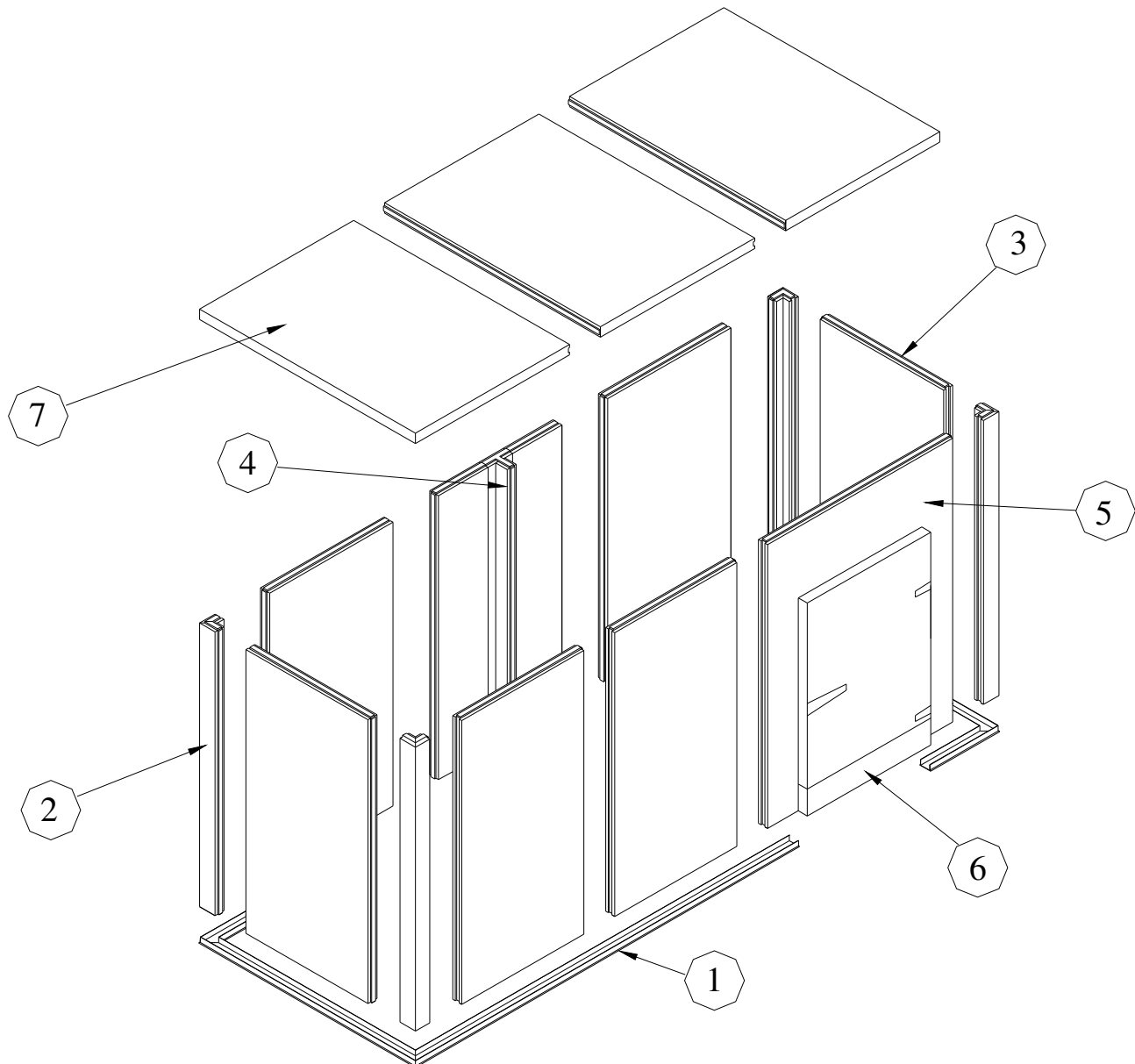

- | | |
|-----------------------------------|-----------------|
| 1. FLOOR SCREED OR COMPLETE FLOOR | 4. "T" CORNER |
| 2. 6" CORNER | 5. DOOR SECTION |
| 3. WALL SECTIONS | 6. DOOR |
| | 7. TOP SECTION |

NOTE:

- * SEAMS BETWEEN TREAD PLATING SHALL BE SEALED USING NSF APPROVED SILICONE SEALANT.
- * PERMANENT JOINTS AND SEAMS SHALL BE SEALED AND SMOOTH USING NSF APPROVED SILICONE SEALANT.

American Cooler Technologies

900 Crandall Parkway
 Lawrence, MI 49064
 Phone: (269) 674-8144
 Fax: (269) 674-3561

FLOOR SCREED INSTALLATION INSTRUCTIONS

1. Use chalk line to locate screed as indicated on the detail screed layout drawing supplied.
2. Each floor screed is numbered at the factory. Following the detail drawing, place the corresponding screed in the correct position as indicated on the layout. Do not deviate.
3. Use transit to level screed and shim as required. Fasten to the floor. Caulk gap between floor & screed with sealer. Run a bead of caulk on the inside of the screed.

NOTE: FOR PROPER COOLER INSTALLATION IT IS MANDATORY THAT THE SCREED IS LEVEL & SQUARE!

STOP: YOU ARE NOW READY TO INSTALL WALL & CORNER SECTIONS.

4. Check screed layout dimensions for accuracy. If the screed is square and level, then proceed to install wall sections as indicated on Wall Installation Instruction Sheet.

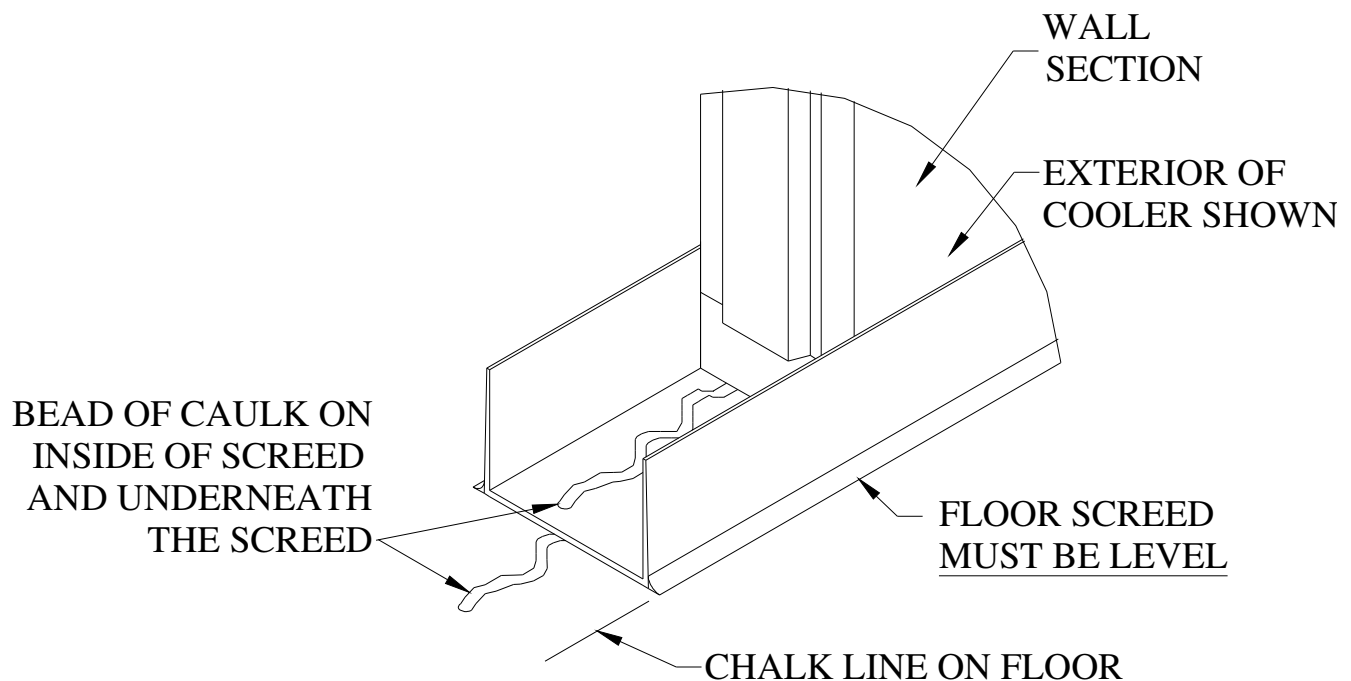

American Cooler Technologies

900 Crandall Parkway
Lawrence, MI 49064
Phone: (269) 674-8144
Fax: (269) 674-3561

WALL INSTALLATION INSTRUCTIONS

NOTE: IF FLOOR SCREEDS ARE LEVEL AND SQUARE, WALL SECTIONS CAN BE INSTALLED FAST AND TROUBLE FREE.

1. Start erecting walls in a corner, which could be inaccessible when placing the last section. Refer to the detailed drawing and match the numbers locating the sections with the numbers on the wall panels and install in both directions.
2. Before locking the section together check the metal on the inside at the top. Sections must be level & plumb in both directions. Shim if necessary.
3. When sections are level, lock together using Allen wrench supplied. Insert wrench in cam lock hole. Rotate wrench clockwise until hook is in the locked position. If hook fails to engage pin, it must be armed. (See drawing below) Finish installing walls at any accessible corner. Insert lock hole plugs supplied.

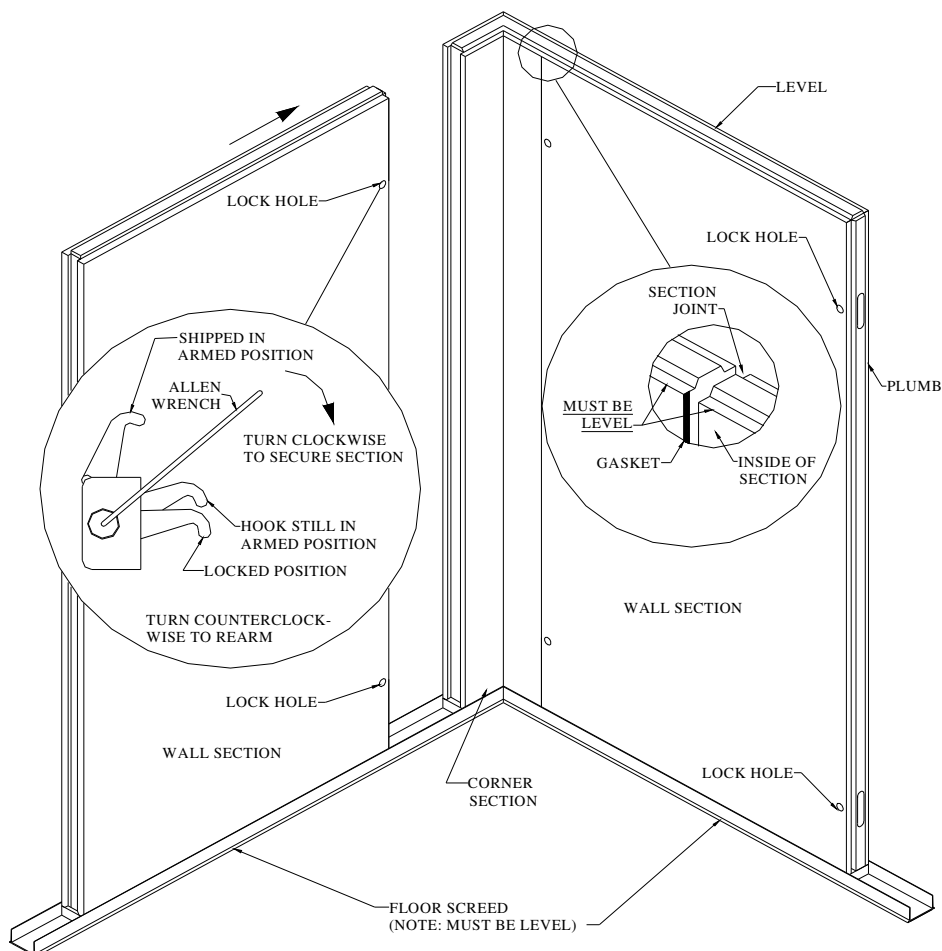

the locked position. If hook fails to engage pin, it must be armed. (See drawing below) Finish installing walls at any accessible corner. Insert lock hole plugs supplied.

American Cooler Technologies

900 Crandall Parkway

Lawrence, MI 49064

Phone: (269) 674-8144

Fax: (269) 674-3561

TOP CAP & TOP CAP TRIM INSTALLATION INSTRUCTIONS

1. Start at an end and install tops as numbered and indicated on the detailed drawing provided. Numbers must correspond for a correct installation. Deviations could result in an incorrect joint location.
2. After tops are all in place and pressed firmly to the wall sections, install the hold down lags, 3/8" x 5" supplied. Tops are all pre-drilled at the factory and a lag **must be used in each hole.**

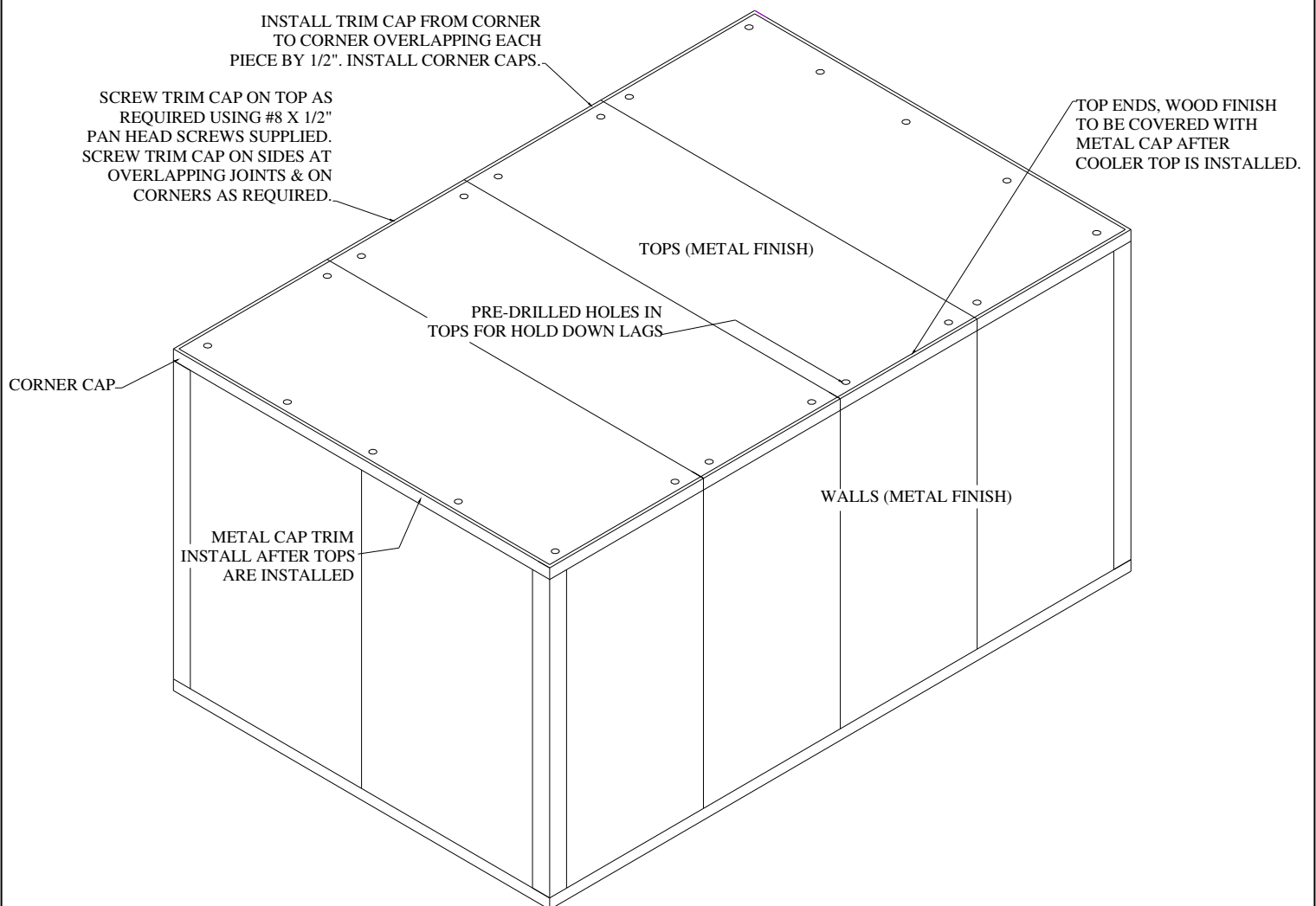

American Cooler Technologies

900 Crandall Parkway
Lawrence, MI 49064
Phone: (269) 674-8144
Fax: (269) 674-3561

DOOR JAMB INSTALLATION INSTRUCTIONS

1. After door sections are in place, loosen lags in shipping bracket and raise to remove wood shipping brace.

DO NOT REMOVE SHIPPING BRACE UNTIL PANEL IS IN PLACE

2. Adjust anchor brackets flush with floor and fasten in place using #14 x 1-1/2 plastic anchor and #14 x 1-1/2 inch pan head screw. (Supplied by ACT)
3. Tighten lags in anchor bracket to door section side jamb.

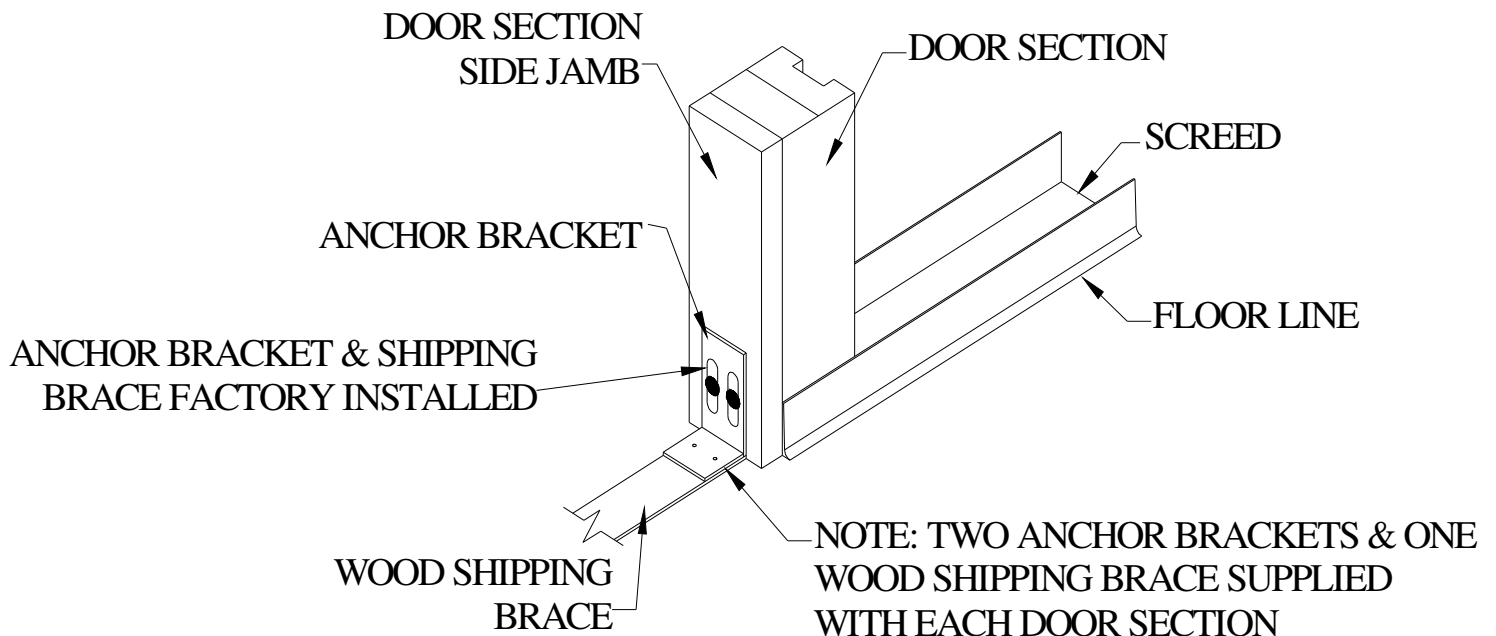

American Cooler Technologies

900 Crandall Parkway
Lawrence, MI 49064
Phone: (269) 674-8144
Fax: (269) 674-3561

TOP CAP TRIM INSTALLATION INSTRUCTIONS

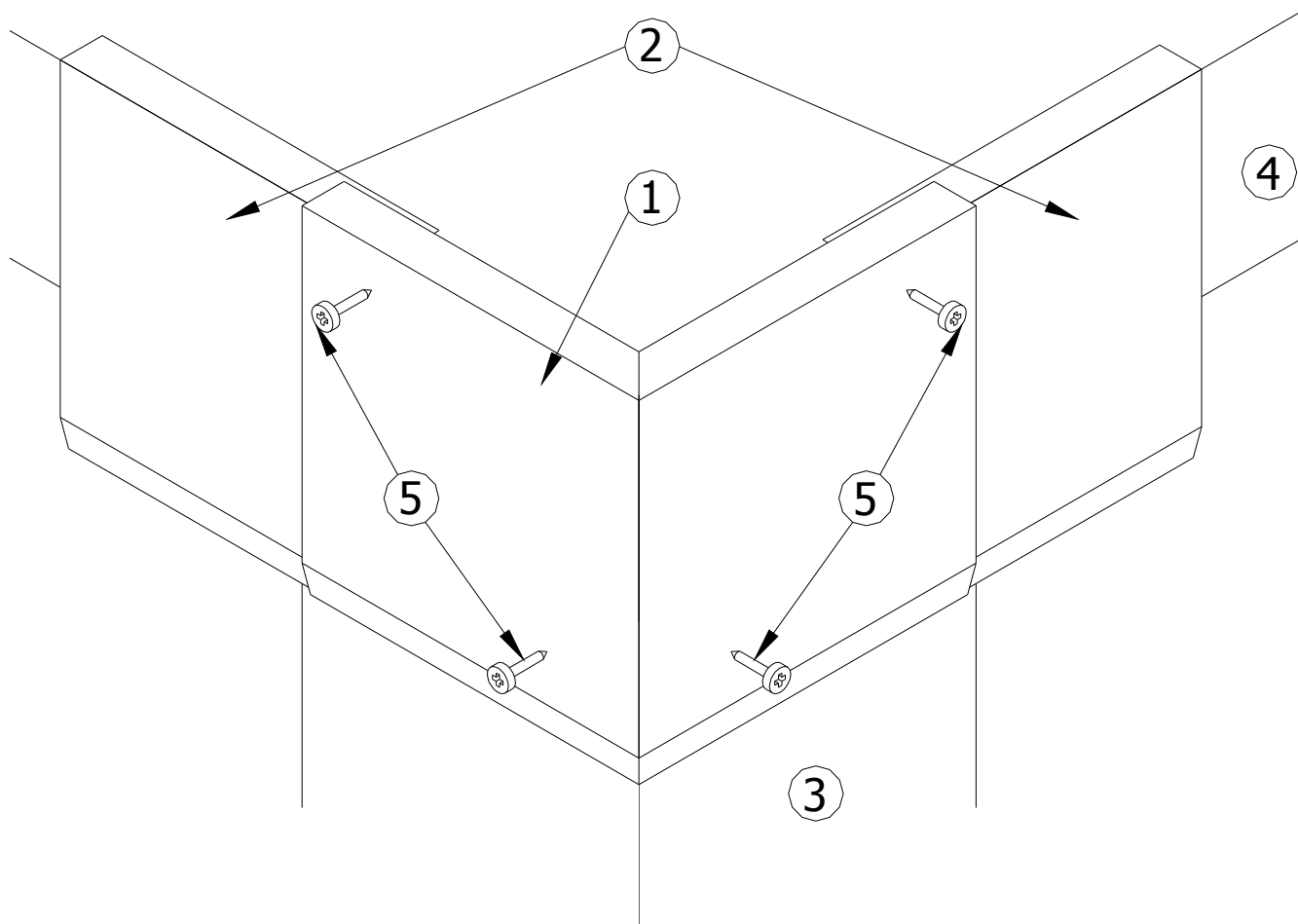

1. Corner piece cap trim. This attaches to the corner to cover the ends of the other cap trim.
2. Cap trim pieces used to cover any exposed wood.
3. Walls that the tops will sit on.
4. 3 1/2" Top
5. Use the 8-18 x 5/8 pan phil tex zinc screws provided by ACT to secure the top trim. 4 screws per corner cap. In the other top trim place screws approximately in the middle of the trim when fastening. Space screws every two feet.

American Cooler Technologies

900 Crandall Parkway
 Lawrence, MI 49064
 Phone: (269) 674-8144
 Fax: (269) 674-3561